

TOX®-Powerpackage line-Q

! The new preferred series !

- Pneumatic press forces from 10 – 300 kN

NEW Short delivery time
NEW Attractive pricing
NEW Magnetic piston for rod position sensing
NEW Latest seal and guidance technology
NEW Extended maintenance intervals

TOX®-Powerpackage line-Q

The new preferred series

NEW Magnetic piston for rod position sensing
NEW Latest seal and guidance technology
NEW Extended maintenance intervals



Advantages of the TOX®-Powerpackage line-Q:

The line-Q drives offer the known advantages of the TOX®-Powerpackage cylinders, which have proven their quality in applications all over the world, with the additional advantages of short lead times and even more attractive pricing.

+ We guarantee for 10 million cycles within 12 months without work-shift restrictions.

Proven TOX® Quality:

- + Pure pneumatic operation (no hydraulic unit required)
- + Simple controls same as any double acting pneumatic cylinder
- + High stroke frequencies
- + High resistance to wear due to few moving parts
- + Saves tooling and reduces noise levels due to low impact forces during fast approach
- + Defined positive stop with damping at bottom dead centre
- + High pressure connection is standard equipment (can be used for sequential controls)
- + Low oil level indicator (maintenance friendly)

Advantages in detail:

The **patented power bypass** protects the oil system from negative pressure, which can be generated in applications, such as punching, shearing, etc. or high cycle speeds. The power bypass is the basic requirement for trouble-free operation of pneumo-hydraulic systems in such applications.

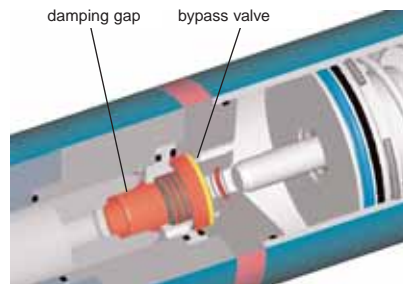

Patented hydraulic end position damping for the return stroke provides for quiet, tool saving operation.

The **double supported** working rod ensures extremely precise guidance.

The absolute **air/oil separation** is a prerequisite for trouble-free operation.

The **ingenious** double function of the **mechanical spring** results in energy savings. No air is used for the return stroke of the intensifier piston, and the automatic preload of the oil reservoir allows for mounting the cylinder in any position.

Accessories:

End position monitoring ZHU

All TOX®-Powerpackages of the line-Q are equipped with a special barrel and a magnet on the working rod to detect the position.



Sensors can be mounted on the tie rods to monitor the cylinder **rod position**. Please order the required number of sensors (ZHS), mounting brackets (ZMP) and cables (length) separately. (See data sheet 10.00, ZHU for the technical data on the switch).

Oil pump ZP

It guarantees the optimum maintenance concept and extended maintenance intervals.

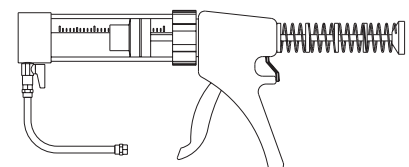

For easy, air-free refilling and reduction of the oil volume of the TOX®-Powerpackage line-Q. Clear body and refill hose allow easy monitoring of the oil level in the pump. Little operator effort required. Capacity 0.30 liters.

Order no.: ZP 20.000

Function of the TOX®-Powerpackage

All application possibilities

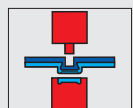

Clinching,
TOX®-sheet metal
joining

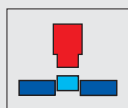

Assembling,
Press-fitting,
Mounting

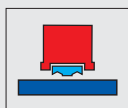

Inserting,
Fastener-Insertion

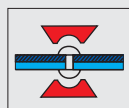

Riveting,
Crimping,
Flaring

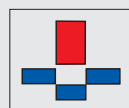

Punching,
Piercing



Coining,
Marking,
Stamping

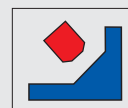

Clamping,
Tensioning,
Peening



Pressing,
Compressing,
Bending

The TOX®-Powerpackage is a pneumatic operated cylinder with automatic activation of the hydraulic power stroke.

The power stroke is automatically triggered as soon as the working rod (tool) meets an opposing force, at any point of the total stroke.

The changeover time can be adjusted with the included throttle valve. With the throttle closed, no power stroke occurs.

(Clinching process shown for clarification)

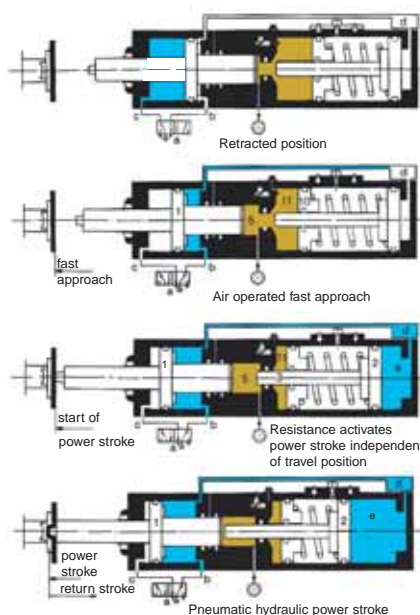

Fast approach – the main control valve “a” is switched. The working piston 1 extends at high speed until it meets resistance at any point of the stroke. This resistance causes the changeover of the included power stroke sequence valve “d”.

Power stroke – the intensifier plunger 3 passes the high pressure seal and compresses the oil in the working area 5 up to 400 bar. This oil pressure acts on the back of the working rod 1 and generates the power stroke.

Return stroke – switching the main control valve “a” again results in switching of the power stroke valve “d” and venting of chamber “e”. The working piston 1 and the intensifier piston 2 return to their initial position.

Controls

It is operated like a pneumatic cylinder and has the press force of a hydraulic cylinder. All that is needed is a standard 4/2 or 5/2 way pneumatic valve such as used with a normal double acting pneumatic cylinder. The included sequence valve controls automatically the changeover from fast approach to power stroke whenever the working rod meets an opposing force during the fast approach.

Investment

The TOX®-Powerpackage is up to 20% less expensive than hydraulic, pneumatic or toggle systems for comparable technical requirements.

Energy consumption

The TOX®-Powerpackage provides up to 90% energy savings compared to pneumatic or hydraulic systems. Energy is used only when needed, namely for the power stroke, barely any for the fast approach and return stroke.

Performance

The TOX®-Powerpackage behaves like a pneumatic cylinder in its operation and cycle speeds. Despite its compact dimensions, it delivers the hard work and high forces associated with hydraulic systems, however, without the need for an expensive hydraulic unit. The TOX®-Powerpackage provides a clean, quiet and reliable operation.

Environment

The TOX®-Powerpackage provides an extremely low noise level due to the hydraulic end position damping in the return stroke. In addition, a low exhaust noise and reduced air consumption. No oil disposal or oil contamination from leakage, no generation of noise such as produced by a constantly running hydraulic pump.

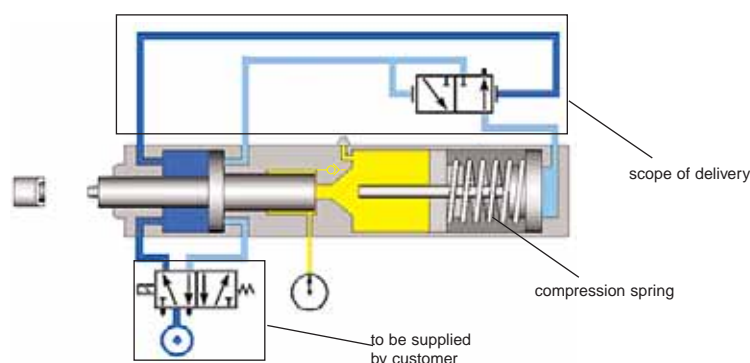

TOX®-Powerpackage line-Q type S at 6 bar 10 - 300 kN

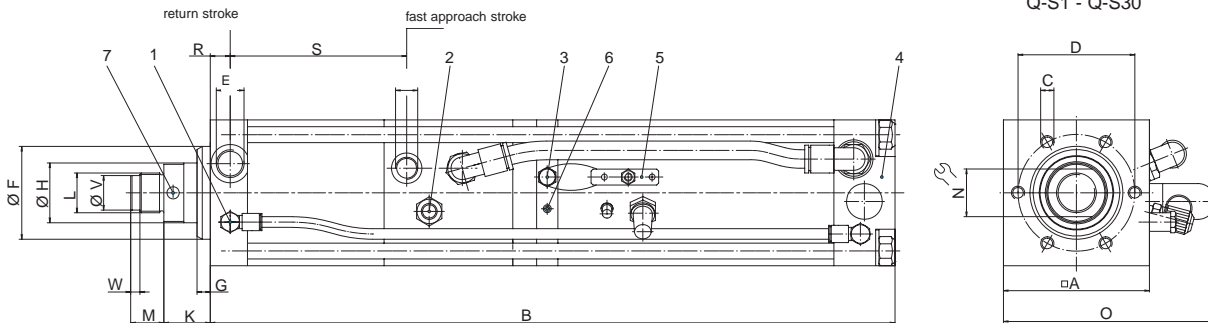

Order No.	included total stroke	max. press force [kN]	fast approach force [N]	return stroke force [N]	A	B	C	D	E	F _{f7}	G	H	K	L	M	N	O	R	S	V _{g6}	W	*IV
Q-S 001.030.100.	22	11,5	1400	1500	70	738	6xM8x12	54	G1/4	40	9	20	26	M16x1,5	15	17	104	13	166	-	-	x
Q-S 002.030.100.	12	17,1	1400	1500	70	738	6xM8x12	54	G1/4	40	9	20	26	M16x1,5	15	17	104	13	166	-	-	x
Q-S 004.030.100.	12	38,1	1700	1950	85	821	6xM8x15	64	G3/8	50	10	30	28,5	M22x2	20	24	124	14	175	18	7	x
Q-S 008.030.100.	12	74,0	3150	3300	110	941	6xM10x16	88	G1/2	70	9	45	35	M30x2	25	36	165	15	183	26	7	x
Q-S 015.030.100.	12	133,7	4500	5400	135	978	6xM16x25	100	G1/2	75	15	50	36	M30x2	25	41	175	17,5	184,5	26	7	x
Q-S 030.030.100.	12	277,0	6600	9250	170	1207	6xM20x30	132	G3/4	100	17	56	47	M39x2	35	50	230	20	236	-	-	-

* IV: integrated sequence valve

Dimensions in mm

TOX®-Powerpackage line-Q type K at 6 bar 10 - 150 kN

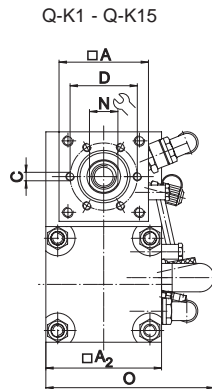
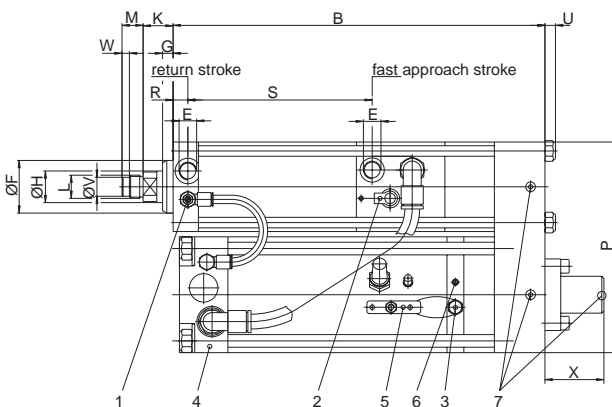

How to order:

Q-S 8.30.100.12

- Power stroke
- Total stroke
- 6 bar series
- Pressforce category
- Execution S/K
- line-Q

- 1 Control throttle X
- 2 High pressure connection
- 3 Oil filling nipple
- 4 Sequence valve approach/power stroke
- 5 Bleed plate
- 6 Oil level indicator
- 7 Bleed screw

Order No.	included total stroke	max. press force [kN]	fast approach force [N]	return stroke force [N]	A	A ₂	B	C	D	E	F _{f7}	G	H	K	L	M	N	O	P	R	S	U	V _{g6}	W	X	*IV
Q-K 001.030.200.	52	11,3	1400	1500	70	85	571	6xM8x12	54	G1/4	40	9	20	26	M16x1,5	15	17	117	160	13	266	8	-	-	244,5	x
Q-K 002.030.200.	34	15,7	1400	1500	70	85	571	6xM8x12	54	G1/4	40	9	20	26	M16x1,5	15	17	117	160	13	266	8	-	-	244,5	x
Q-K 004.030.200.	13	47,0	1700	1950	85	110	597	6xM8x15	64	G3/8	50	10	30	28,5	M22x2	20	24	165	200	14	275	10	18	7	204,5	x
Q-K 008.030.200.	18	69,0	3150	3300	110	135	626	6xM10x16	88	G1/2	70	9	45	35	M30x2	25	36	177	250	15	283	12	26	7	229,5	x
Q-K 015.030.200.	12	140,0	4500	5400	135	170	650	6xM16x25	100	G1/2	75	15	50	36	M30x2	25	41	231	315	17,5	284,5	16	26	7	185,5	-

* IV: integrated sequence valve

Dimensions in mm